

Drop-In Drop-in refrigerated well, static (3 GN container capacity) with A overshelf

ITEM # _____

MODEL # _____

NAME # _____

SIS # _____

AIA # _____



341178 (D10C30)

Drop-in Refrigerated Well,
static (3 GN container
capacity) with one A type
overshelf and LED light

Short Form Specification

Item No.

Hydrocarbon refrigerant gas R290 for the lowest environmental impact (GWP=3) - CFC and HCFC free. Designed to serve the food in gastronorm containers. Suitable for GN 1/1 containers with a maximum height of 200 mm. Well in 304 AISI stainless steel with rounded corners to facilitate cleaning operations. The well is also equipped with a drain hole. Automatic defrosting guarantees evaporators clearance and efficient well cooling. High-density expanded polyurethane foam with cyclopentane guarantees excellent well insulation to reduce energy dispersion. The bottom is equipped with copper tubes to ensure proper cooling, with this system the air touches the cold surface and gets cooled. Stylish A type overshelf designed for extra increased visibility on the surface for charming food display. Overshelf equipped with LED lights.

Main Features

- CB and CE certified by a third party notified body.
- Designed to serve the food in gastronorm containers.
- Suitable for GN 1/1 containers with a maximum height of 200 mm.
- Precise temperature control and setting at 0,1°C .
- As standard the product comes with digitally controlled thermostat which is in line of HACCP norms and provides visual alarm as a warning of the increasing or decreasing temperatures.
- Food introduced at the correct temperature maintains its core temperature according to Afnor Standards.
- Automatic defrosting guarantees evaporators clearance and efficient well cooling.
- Stylish A type overshelf designed for extra increased visibility on the surface for charming food display.
- Overshelf equipped with LED lights.
- Designed to be positioned in flush installation providing improved cleanability and suitable for modern design installations.

Construction

- Electronic control with temperature display.
- Well bottom is inclined to facilitate water drainage.
- Well in 304 AISI stainless steel with rounded corners to facilitate cleaning operations. The well is also equipped with a drain hole.
- IPx2 water protection.
- The bottom is equipped with copper tubes to ensure proper cooling, with this system the air touches the cold surface and gets cooled.
- Overshelf in complete AISI 304.

Sustainability

- Hydrocarbon refrigerant gas R290 for the lowest environmental impact (GWP=3) - CFC and HCFC free.
- High-density expanded polyurethane foam with cyclopentane guarantees excellent well insulation to reduce energy dispersion.

APPROVAL: _____

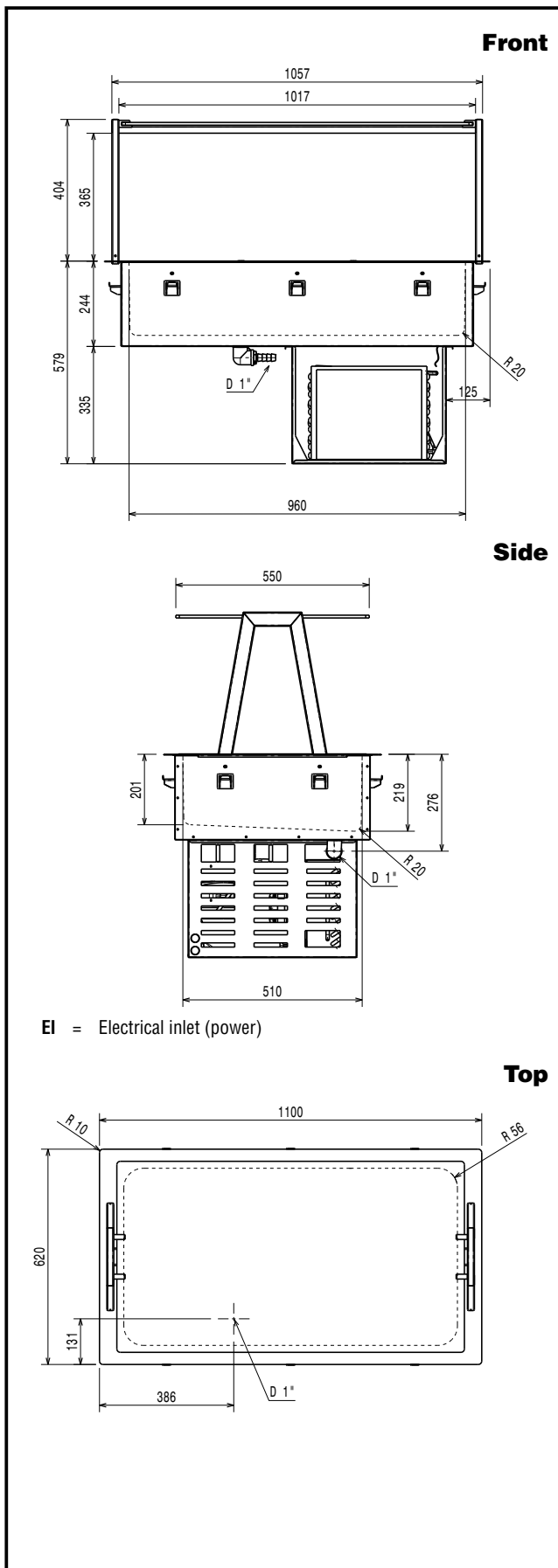

Electric

Supply voltage:

341178 (D10C30)

220-240 V/1N ph/50 Hz

Electrical power max.:

0.54 kW

Water:

Water drain outlet size:

Key Information:

External dimensions, Width: 1100 mm

External dimensions, Depth: 620 mm

External dimensions, Height: 999 mm

Net weight: 67.68 kg

Shipping weight: 92 kg

Shipping height: 1160 mm

Shipping width: 670 mm

Shipping depth: 1140 mm

Shipping volume: 0.89 m³

Set temperature: -15 / 0 °C

Refrigeration Data

Refrigerant type:

R290

Sustainability

Noise level:

56 dBA